

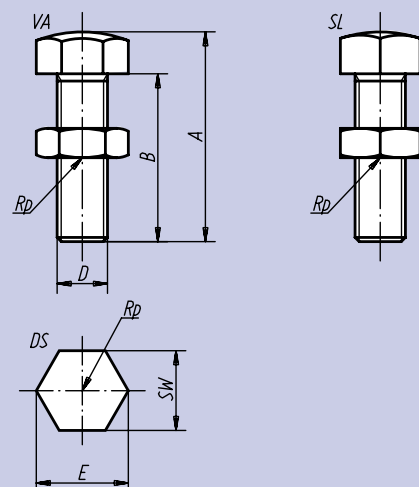

Matière, Finition:
Acier traité.
Trempe et bruni.
* Laiton.

Exemple de commande:
nlm 02153-16055



Référence	A	B	D	E	SW	kg
02153-08036	36	30	M 8	15,0	13	0,020
02153-10042	42	35	M10	19,6	17	0,040
02153-12048	48	40	M12	21,9	19	0,055
02153-16055	55	45	M16	27,7	24	0,114
02153-12148*	48	40	M12	21,9	19	0,061
02153-16155*	55	45	M16	27,7	24	0,127



Matière:
Acier traité.

Finition:
Peinture, filet trapézoïdal auto-bloquant, vis à frein intégré.

Exemple de commande:
nlm 02170-02

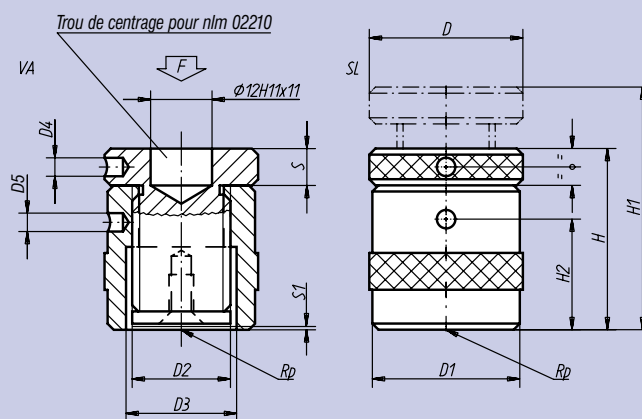

Référence	D	D ₁	D ₂	D ₃	D ₄	D ₅	H	H ₁	H ₂	S	S ₁	F _{max} kN	kg
02170-01*	31	31	Tr 20 x 4	23	4	4	38	52	23	8	2,0	15	0,190
02170-015	50	49	Tr 30 x 4	36	6	6	42	52	24	12	2,5	60	0,550
02170-02	50	49	Tr 30 x 4	36	6	6	50	72	30	12	0,5	60	0,620
02170-03	50	49	Tr 30 x 4	36	6	6	71	102	43	16	1,5	60	0,900
02170-04	65	70	Tr 40 x 7	43	6	6	100	140	58	25	2,5	100	2,635
02170-05	70	80	Tr 50 x 8	55	6	6	140	212	90	30	4,0	170	4,600
02170-06	80	100	Tr 60 x 10	70	6	8	190	300	126	34	5,0	350	9,000

* Cette taille n'est pas munie de trou de centrage Ø 12.

